



Series
NSX

SIZE 8 FRONT RELEASE. FRONT REMOVABLE
TIN LEAD PC POST PIN QUADRAX CONTACT

Issue:
07 MARCH 02

Page
1 / 1

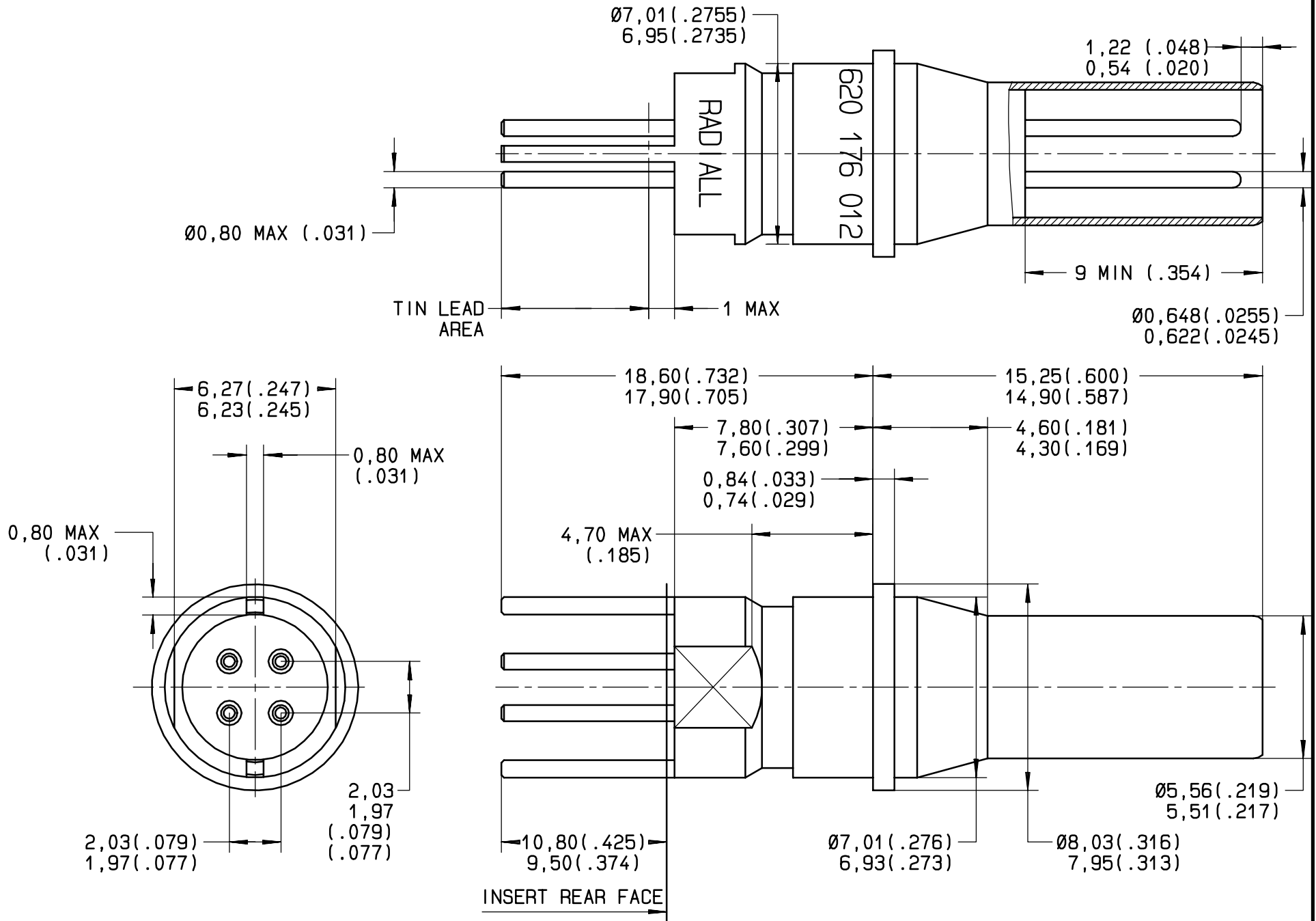

This information is given as an indication. In the continual goal to improve our products, we reserve the right to make any modifications judged necessary.

**RECOMMENDED
PC DRILL PATTERN**

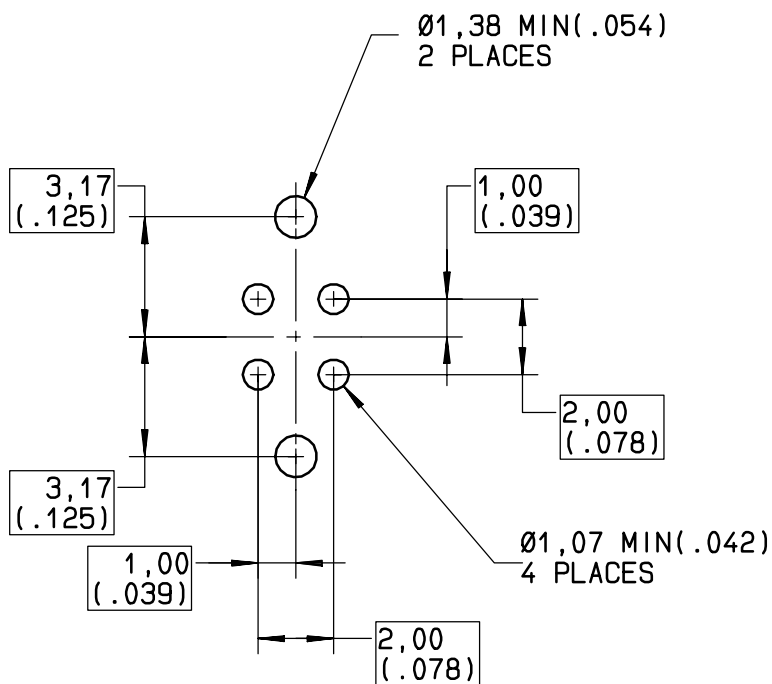

***MATERIAL:**

- OUTER CONTACT: BRASS PER QQ-B-626
- CENTER CONTACT: BODY LEADED NICKEL COPPER (C97)
- DIELECTRICS: FPTE PER ASTM-D-1710 OR EQUIVALENT

***FINISH:**

- ALL METAL PARTS:
PLATING .00005 INCH OF GOLD PER MIL-G-45204 TYPE I OR II
GRADE C OR D CLASS 1 OVER NICKEL PER QQ-N-290 - PWD SOLDER
CONTACT AREA WHICH IS TIN LEADED PER QQ-S-571

***EXTRACTION TOOL:**

- RADIAL P/N: 282 549 009

CREATION
PEN: M000104382C
NOM: COUTHON
DATE: 07 MARCH 02
APPR.:
Issue	Revisions		Name	Approved